

SPIROCOMBI® MAGNET
SPIROTRAP® MAGNET

Magnetite: circulation or removal?

NEW

SpiroCombi and SpiroTrap
with built-in magnet for
even faster dirt separation



The safest and most user-friendly way to remove dirt from large systems

The SpiroCombi Magnet and SpiroTrap Magnet collect magnetic and non-magnetic dirt particles in pipe systems quickly and effectively. In particular, the user-friendly design and high level of safety make these products unique. Dirt is discharged in no time at all.

Benefits SpiroCombi and SpiroTrap with magnet

- Provides superb protection for pumps with magnetic rotors and other expensive system components against (magnetic) dirt.
- Extremely easy to use: dirt is discharged quite easily using a drag mechanism.
- No safety risks: the magnet remains in the unit.
- Maintenance-free magnet.
- No additional space required for installation (in height).
- Robust and leak-free, with large-volume dirt collection capacity.
- Highly efficient separation of both magnetic and non-magnetic dirt particles (from 5 µm!).
- 5-year guarantee.

1. The dry-pocket construction is at the core and specially designed for the optimum collection of magnetite.
2. The unique SpiroTube. This component carries out deaeration and dirt separation and has very low resistance.
3. Cone. This neutralises the magnetic field: the magnetic dirt that passes this cone is discharged by releasing the magnetic force.
4. Drain valve for discharging the dirt collected.
5. Flexible drag mechanism. By sliding the mechanism downwards, magnetic dirt is dragged via the dry-pocket construction and collects at the bottom of the unit.

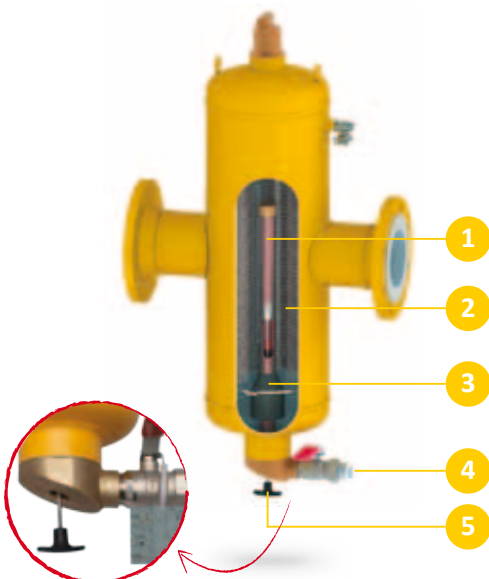

Deaerator and dirt separator with unique magnetic field booster technology

Provides superb protection for pumps with magnetic rotors and other expensive system components against magnetite.

In particular, the new generation of pumps with magnetic rotors attracts magnetic dirt which settles on expensive components and speeds up the process of wear. The result: reduced performance due to the impaired functioning of the boiler, faults and sometimes even failure.

The SpiroCombi Magnet and SpiroTrap Magnet deliver extremely effective separation of both magnetic and non-magnetic dirt. The innovative dry-pocket construction at the core collects the magnetic dirt (magnetite).

The magnetite is dragged downwards by the flexible drag mechanism and collects at the bottom of the unit. The operation of the SpiroTubes is directed inwards to ensure highly effective dirt separation and collection of all non-magnetic dirt. When the drain valve is opened, the dirt is flushed out quickly and effectively due to the system pressure.

In particular, ease of use, simplicity and the speed with which dirt collected can be discharged have made these products an unrivalled success. The compact design of the unit means that no extra installation space is required. The magnet remains at the core of the unit, is maintenance-free and is always mounted correctly.



The SpiroCombi Magnet and SpiroTrap Magnet are available in sizes DN50 up to and including DN100 as standard. Coming soon: sizes DN125 and DN150.

Technical data								
	SpiroTrap Magnet				SpiroCombi Magnet			
Product number* ¹	BE050	BE065	BE080	BE100	BC050	BC065	BC080	BC100
Weight LM [kg]	8	8	16	16	11	11	23	24
Weight FM [kg]	13	14	24	25	16	17	31	32
Connection [DN]	50	65	80	100	50	65	80	100
Connection OD [mm]	60,3	76,1	88,9	114,3	60,3	76,1	88,9	114,3
L [mm]	260	260	370	370	260	260	370	370
LF [mm]	350	350	470	475	350	350	470	475
H [mm]	475	475	600	600	730	730	890	890
Normal flow 1,5 m/s* ²								
Max. flow [l/s]	3,5	5,5	7,5	13	3,5	5,5	7,5	13
Max. flow [m ³ /h]	12,5	20	27	47	12,5	20	27	47
Δp at max. [kPa]	3	2,7	2,9	3,7	3	2,7	2,9	3,7
Maximal flow 3 m/s* ²								
Max. flow [l/s]	7	11	15	26	7	11	15	26
Max. flow [m ³ /h]	25	40	54	94	25	40	54	94
Δp at max. flow [kPa]	11,8	11,6	12,4	14,6	11,8	11,6	12,4	14,6

*¹ for welded models, add LM (e.g. BE050LM), for models equipped with a flange, add FM (e.g. BE050FM)

*² Standard steel Spirotech products are designed for a nominal flow velocity of up to 1.5 m/s. With higher velocities, the increased turbulence will not always leave a sufficiently quiet zone for optimum separation in a standard unit. A higher flow velocity will also result in a significantly increased drop in pressure. In order to avoid systematically higher flow velocities (> 1.5 m/s), we recommend choosing a larger connection size. This will achieve the same flow rate, but with a lower flow velocity, ultimately resulting in a higher separation output and a lower drop in pressure (reduced energy loss).

Spirotech is part of Spiro Enterprises.



Spirotech bv
 PO Box 207
 5700 AE Helmond, NL
 T +31 (0)492 578 989
 F +31 (0)492 541 245
 info@spirotech.nl
 www.spirotech.com

Spirotech UK Ltd.
 PO Box 818 Altrincham
 Cheshire, WA15 5GZ
 T +44 (0)208 451 3344
 F +44 (0)208 451 3366
 info@spirotech.co.uk
 www.spirotech.co.uk

Total solutions

Spirotech offers a wide range of total solutions for HVAC and process systems: fittings, additives and advice on how to use and assure the quality of the system fluid as effectively as possible. These products and services will reduce faults, wear and maintenance and also improve the performance of the system while reducing energy consumption. These total solutions will also provide major benefits and save time when it comes to the design, installation, start-up and controlling of systems.

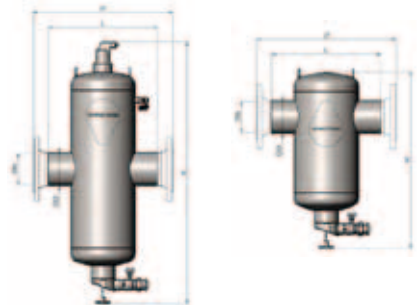

Drawings and situations in this brochure are only examples. We would be pleased to give you advice regarding more specific situations. Amendments and printing and typing errors reserved.
 © Copyright Spirotech bv. No part of this publication may be used without prior written consent from Spirotech bv.

